

Everllence



Fuel-efficient hybrid
propulsion system

HyProp ECO

An aerial photograph showing the wake of a boat moving through a narrow fjord. The water is a deep blue, and the wake is a white, frothy trail that curves through the water. In the background, there are green, forested hills and a small island with a few buildings. The sky is a clear, light blue.

Moving big things to zero

The global maritime industry faces major challenges complying with strict environmental standards, especially in terms of emissions, without sacrificing propulsion efficiency and ship performance. Depending on the power demand and operation profile of the vessel, this must naturally result in more than one type of propulsion system.

For many merchant vessels such as tankers or cargo vessels with a peer-to-peer operation profile, where the vessels have long periods of constant sailing, this can be achieved by a diesel-mechanic propulsion system designed to match the power demand of the vessel at service speed.

On vessels with more flexible operation profiles and running hours with both high and low power demands, a hybrid propulsion system is often better suited for the changes occurring during the vessel's trip or even for the vessel's lifetime.

Hybrid in the present context implies that mechanical and electric power is combined in the propulsion train, therefore optimizing the propulsion efficiency. The total propulsion power is delivered by a combination of mechanical power supplied by diesel engines and electric power provided by electric motors. This combination gives the vessel a broad operational capability and provides the right amount of power and torque to the propeller in each operation mode. There is a need for a smart solution which provides shipowners and operators with a well-balanced and tailor-made propulsion plant in terms of flexibility and performance.

With HyProp ECO, it is possible to:

- Reduce the fuel oil consumption by 10 – 15 %
- Reduce CO₂ and supports to meet the ship's GHG targets
- Operate the propeller with the highest efficiency at its best hydrodynamic point
- Reduce the operating hours of auxiliary gensets, resulting in lower maintenance costs
- Avoid electrical losses in all operation modes, where a bypass of the variable speed drive (VSD) can be used

HyProp ECO is an advanced and flexible hybrid propulsion system for controlling the power delivered by or to the shaft machine in the most efficient way. It overcomes the constraint on constant speed propulsion machinery by utilizing VSD technology at the shaft generator / motor. This means that the power take-off / power take-in (PTO / PTI) operates at variable propeller speed and an optimal utilization of the main engine is thereby achieved, which is not possible in a conventional PTO / PTI installation with constant propeller speed. In PTO mode, the VSD provides a constant frequency and voltage towards the main switchboard while operating the propeller according to the efficient combinator curve.

Saving fuel oil

by reducing propeller and main engine speeds

Achieving a fuel oil reduction means understanding the two starting points for fuel oil saving: the propeller and the main engine.

The CP propeller and attached PTO

Everllence Alpha controllable pitch propellers (CPP) are designed with the highest hydrodynamic efficiency and with a focus on controlling cavitation, pressure pulses, vibration and noise. The Kappel blade design is a key feature in achieving a highly efficient free-running propeller. On top of that, fairing cones and rudder bulbs may be placed upstream or downstream the propeller for even higher efficiency. If thrust and pulling performance matter, a propeller nozzle is also a good solution for achieving high efficiency and high thrust customization of the propeller.

In a propulsion optimization process, it is always necessary to adapt the propeller to the individual ship application. Careful assessments of operational power, speed and duration profiles of the vessel are decisive for finding the perfect propeller layout. The relationship between propeller power and propeller speed is crucial in understanding why it is beneficial to reduce the propeller speed when the ship is not sailing at its design speed. Fig. 1 shows an open water diagram of the CPP with different pitch adjustments ranging from $P/D = 0.7$ to 1.3, while the corresponding PD-n diagram is shown in Fig. 2.

Wageningen B-series KT-KQ-J chart

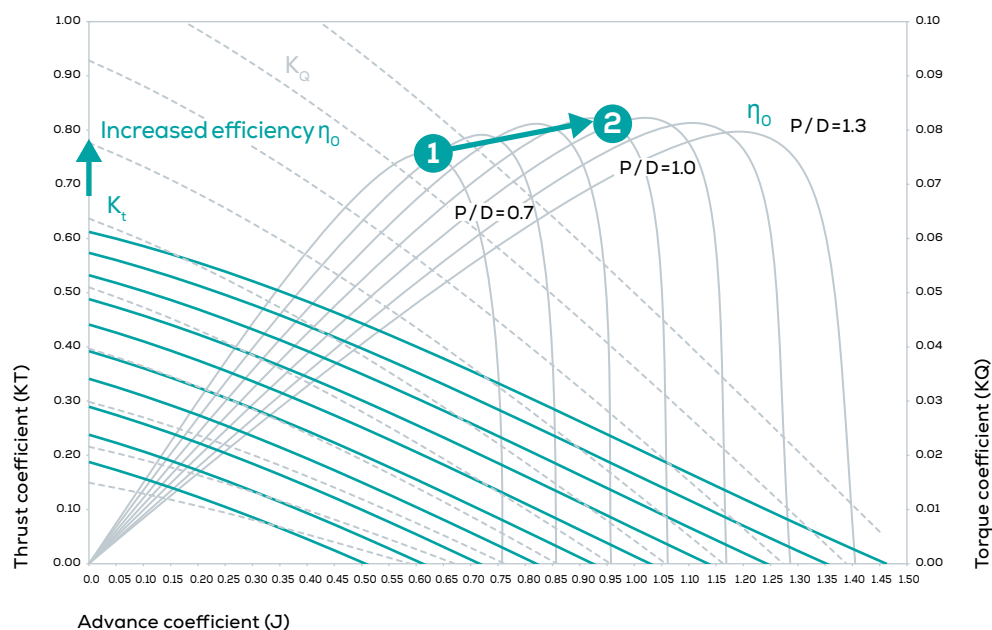

Fig. 1
Open water diagram of the CPP with different pitch adjustments from $P/D = 0.7$ to 1.3

The propeller is designed to deliver maximum power at maximum rotational speed at the vessel's design speed.

For simplification reasons, no margins are considered in the example. The vessel reaches its design speed and highest speed of 21 knots at 145 rpm and it consumes 12.5 MW. The propeller is designed for this operating point with the best possible pitch (here $P / D = 1.2$). When a ship with a standard constant speed propulsion plant is sailing at a reduced speed of 16 knots, the pitch is reduced (here to $P / D = 0.7$), whereas the propeller speed is kept constant at the rated 145 rpm. This is mainly due to the PTO shaft alternator which is attached to the reduction gearbox. A PTO is often the most economical source of electric power generation on board the vessel, as it generates power directly from the main engine, which is usually much more fuel-efficient compared to auxiliary gensets. The PTO is generally the cheapest way of producing electric power on board a vessel powered by a four-stroke medium speed engine.

Fig. 1 and Fig. 2 show that constant speed operation of the propeller, with a reduced pitch for obtaining a lower sailing speed, is not the best way to operate the propeller. It is more efficient to reduce the speed of the propeller, i.e. to 116

rpm, and to use a propeller pitch setting which is in the same range as the design point. In this case, it will increase propeller efficiency by 700 kW. This effect becomes even more pronounced as the vessel's sailing speed decreases. The PTO alternator often hinders usage of the combinator mode. Non-constant speed operation of the PTO means that its input speed is no longer constant and does not match the synchronous speed of the PTO alternator. The synchronous speed of an alternator follows the equation below:

$$s = 2 \times 60 \times f / p$$

The speed (s) is measured in rpm, the frequency (f) in hertz and (p) is the pole number, which is an even number determined by the alternator design.

The implication of the equation is that the PTO cannot generate a constant frequency at the output terminals. It is not possible to produce a frequency that is constantly equal to 60 Hz independent of the vessel speed (here it produces 48 Hz at 16 knots). Therefore, the PTO can no longer power the ship or run in parallel with the auxiliary gensets. The result is that the auxiliary gensets always have to be used in cases where the propeller operates according to the combinator curve. This usually does not pay off.

The medium speed engine

Everllence offers a range of fuel-efficient, powerful and reliable medium speed engines with features such as low fuel oil consumption, low emissions in accordance with IMO regulations and the best performance over the entire load range. Especially the common rail (CR) injection technology used in the popular L&V32/44CR and L&V48/60CR engine series provides the engines with an efficient load response, quick acceleration and smokeless operation at part-load and full-load.

The common rail technology offers flexible setting of the injection timing, pressure and duration for each cylinder. This flexibility allows optimization of the fuel oil consumption and the engine emissions at any point on the operation map.

Fig. 3 shows a typical engine operation map for a CR engine with possible fuel oil savings indicated in g/kWh. It is apparent from the diagram that if the operation of the engine is following a given combinator curve (shown in red) of the CP propeller, this is the most fuel-efficient way to operate it, even if the engine is operating at a reduced speed at part-load. The same argument applies to the propeller. It enables the designer to find a curve which coincides with all the minimal points for fuel oil consumption over almost the complete power or load range. Both the propeller and the diesel engine show improved behavior in part-load operation, confirming the perception that the key to fuel oil saving is a reduced propeller and engine speed. From a propulsion system perspective, it becomes clear that a smart hybrid system should facilitate operation modes where the above-mentioned savings can be utilized.



Fig. 3
Relative engine operation map for a CR engine

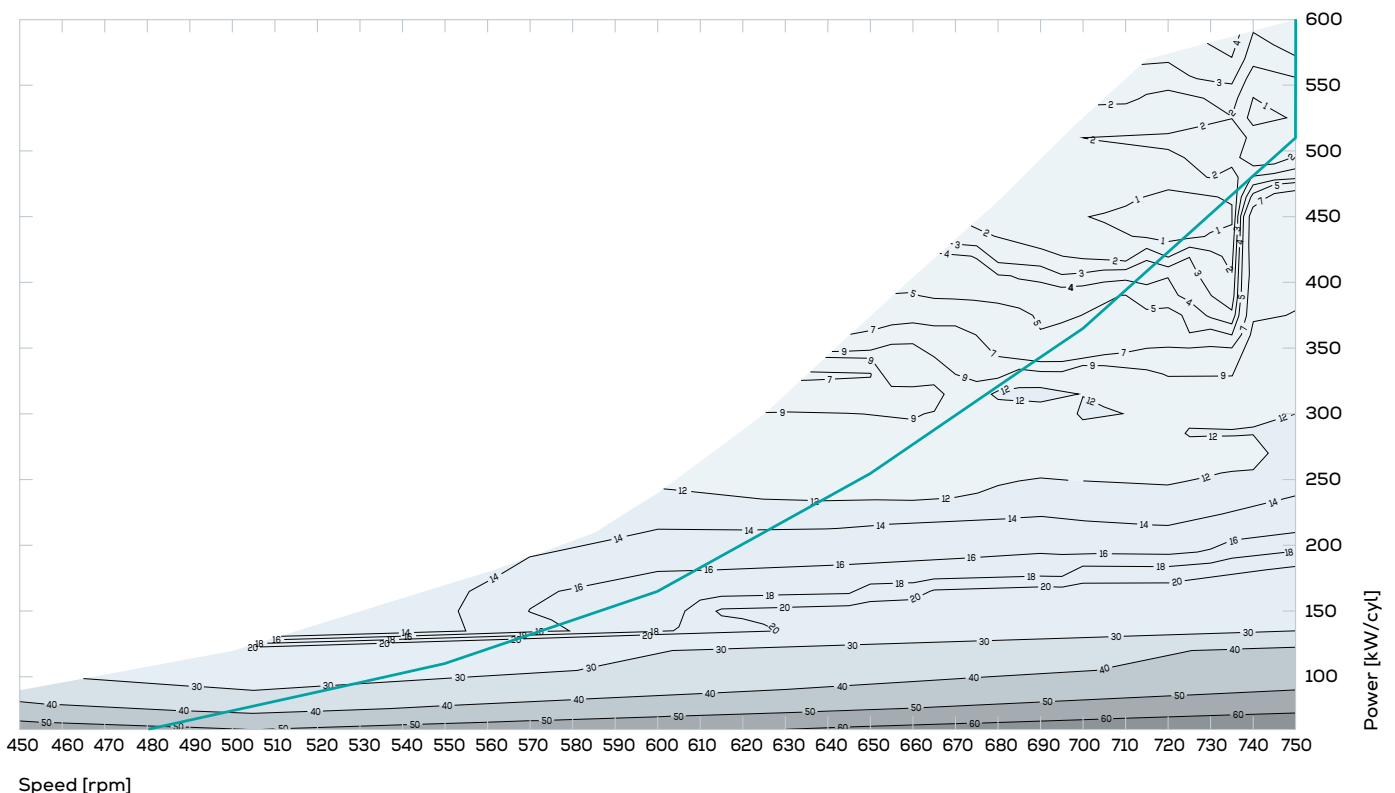

System overview

Main components

HyProp ECO is a system solution that combines the CP propeller, the diesel engine and the electric shaft machine (alternator / motor) in an intelligent way.

- 1 Controllable pitch propeller (CPP)
- 2 Shaft alternator / motor (PTO / PTI / PTH)
- 3 Reduction gearbox
- 4 Main engine (four-stroke, medium speed engine)
- 5 HyProp ECO bypass
- 6 HyProp ECO VSD unit
- 7 Main switchboard (typically 440 V or 690 V)
- 8 Auxiliary gensets (medium speed or high speed auxiliary gensets)

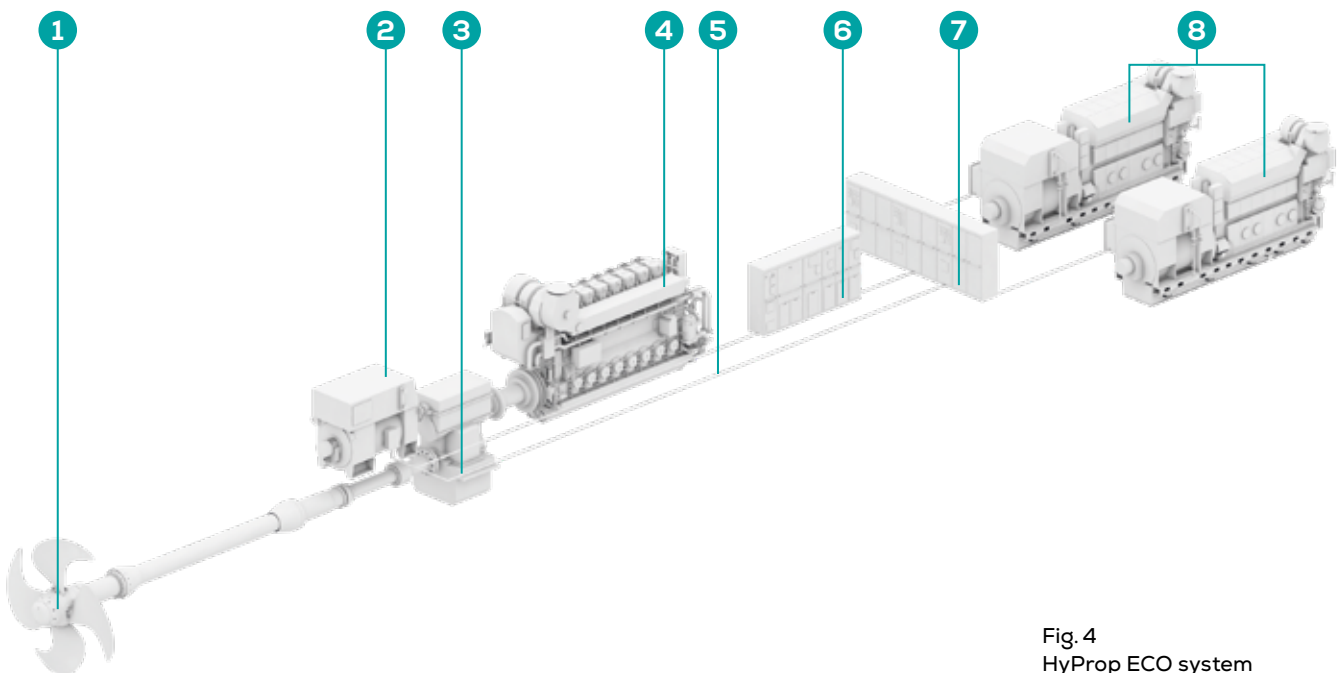

Fig. 4
HyProp ECO system

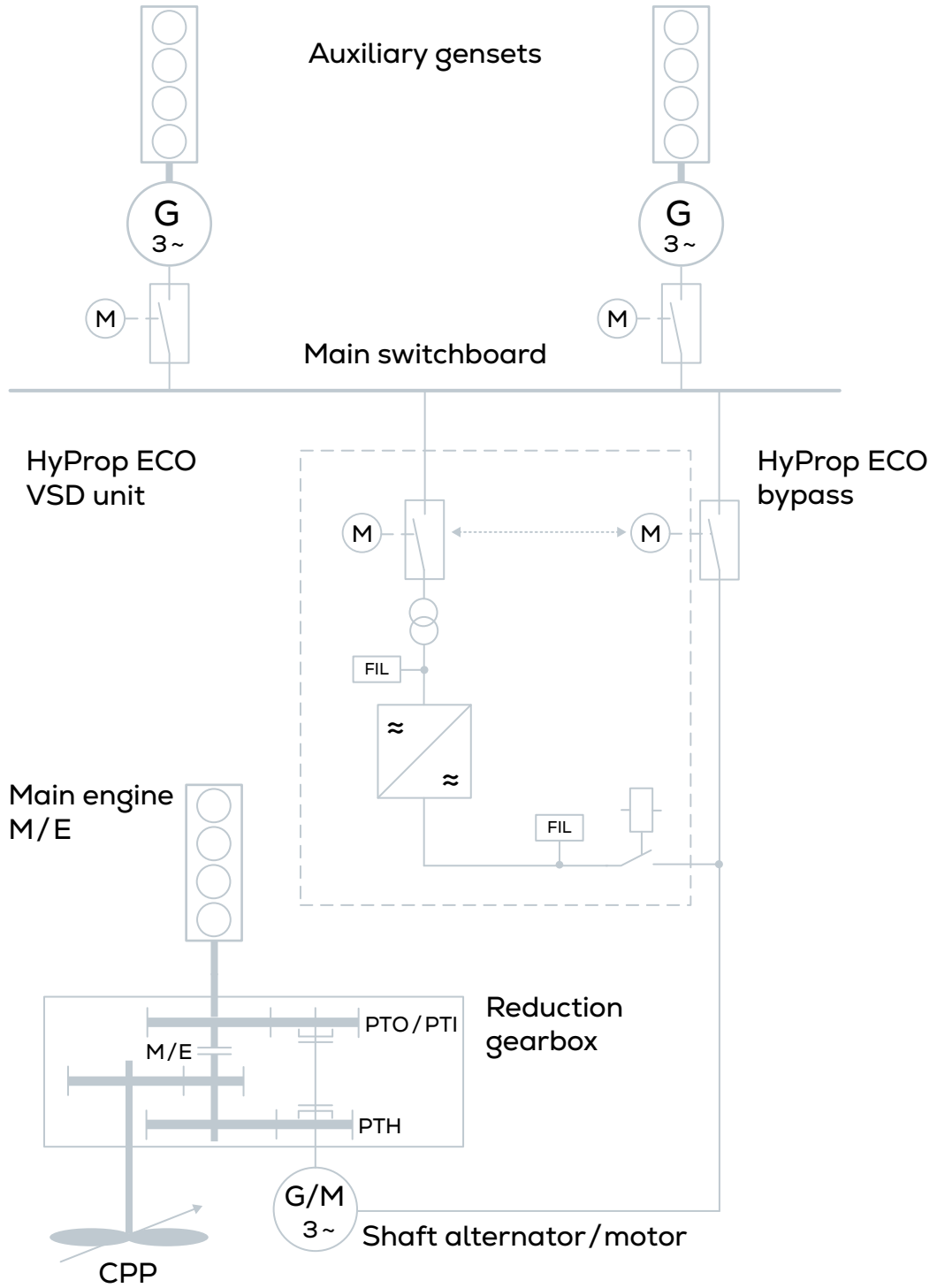

Fig. 5
HyProp ECO system

On a functional level, HyProp ECO can be described by the simplified single-line diagram in Fig. 5.

Apart from the main engine (M/E) and the CP propeller, the VSD unit determines the functionality of the system. It is a modular system and the total power needed to control the shaft alternator / motor can be obtained by combining several smaller units. In this way, the redundancy is increased since each unit is able to run independently.

HyProp ECO operates at low voltage levels, i.e. 380 – 500 VAC or 525 – 690 VAC, depending on the voltage of the main switchboard. The

enclosures of the cabinets have IP54 rating, which withstands the harsh operating conditions on board a vessel. The cabinets are either air or liquid cooled, which gives the HyProp ECO panels their compact design with a small width and light weight. All internal filters needed to fulfill the class requirements in terms of total harmonic distortion and to protect the windings of the shaft alternator / motor are included.

Fig. 6 shows the basic components of the HyProp ECO VSD unit.

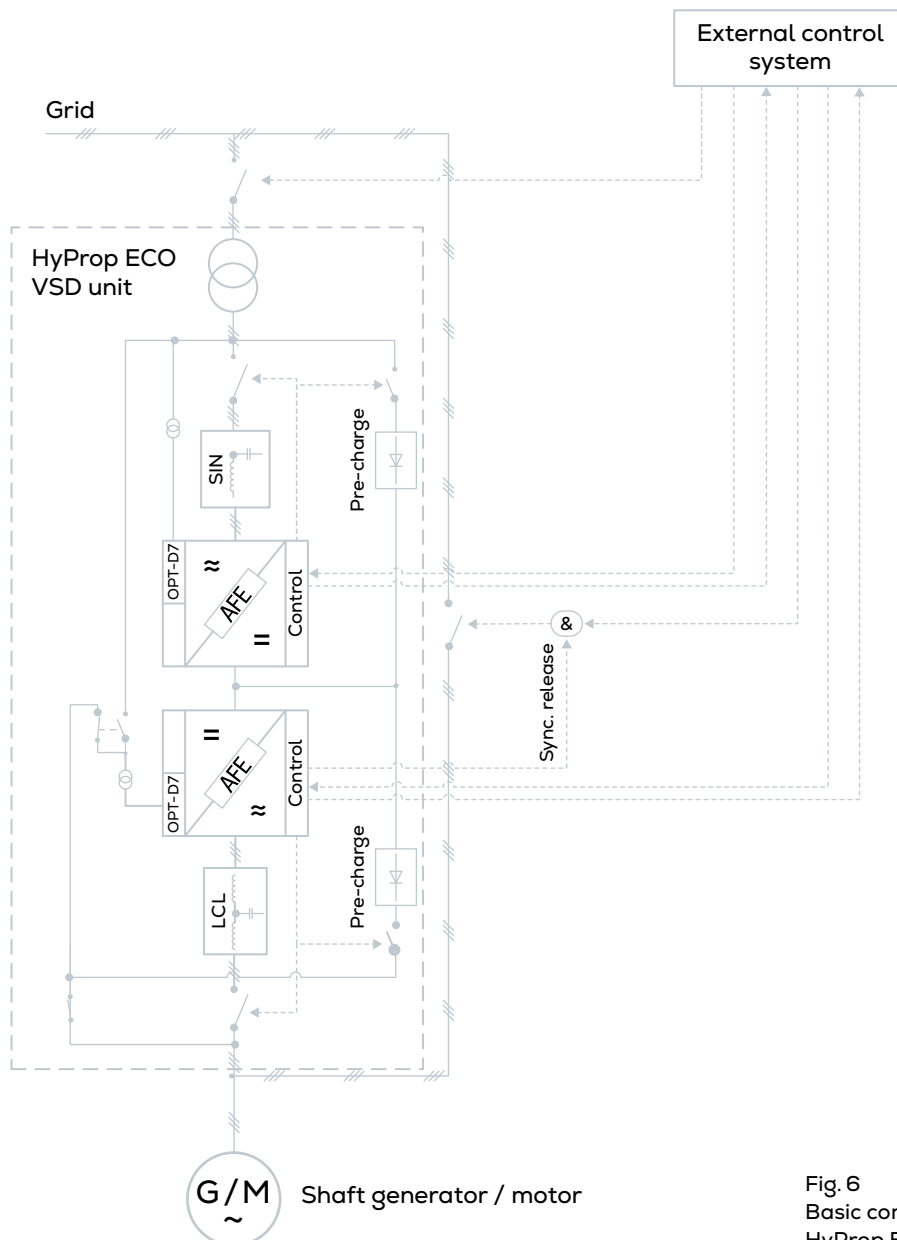

Fig. 6
Basic components of the
HyProp ECO VSD unit

Operation modes

Flexibility of HyProp ECO



HyProp ECO is a very flexible system which allows several operation modes. This means that it is always possible to find the optimal mode in terms of propulsion train performance and fuel oil consumption.

Mode one: PTO and PTI boost

Mode one focuses on the efficient operation of the shaft machine, either as a source of electric power for the vessel's consumers (PTO) or as a source of auxiliary power to boost the propeller (PTI). In PTI mode, the main engine and the auxiliary gensets operate in parallel, whereas in PTO mode, the shaft machine is often the only electric power generator. This is economic due to the better specific fuel oil consumption of the main engine compared with the much smaller

auxiliary gensets. In mode one, there are no losses in the electric transmission from the shaft machine to the main switchboard as the bypass is used. Typically, the total loss for the VSD unit (including the transformer and filters) is 7 %. Mode one can also be used for economical slow steaming of a twin-screw application with only one main engine in operation. The PTI on the second shaft can also be supplied by the PTO via an electric cross connection.

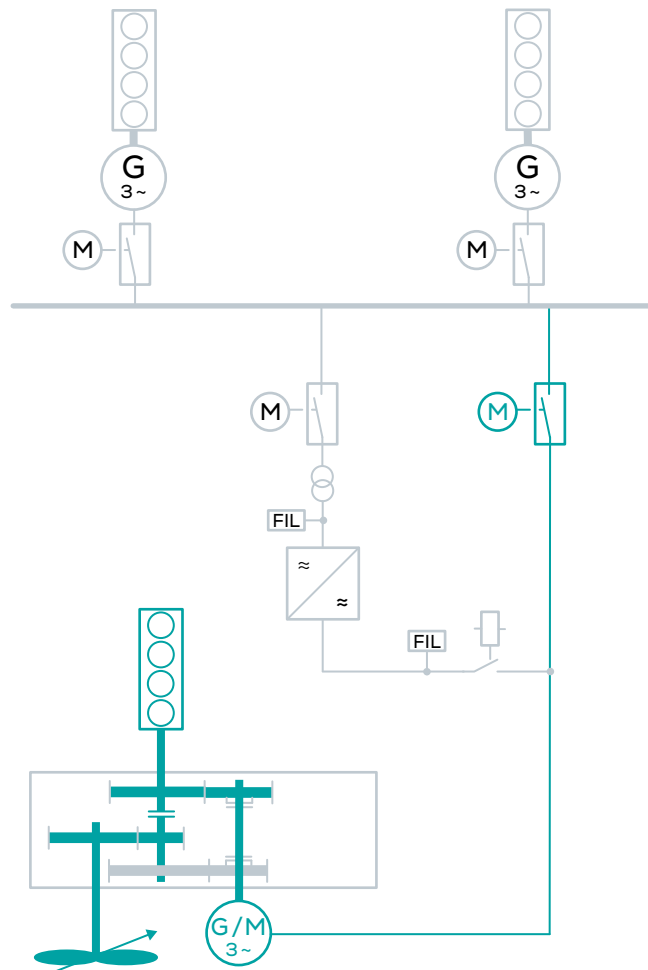

Fig. 8
Gensets can operate in parallel with PTO and are in operation for PTI boost

Mode two: PTO eco

Mode two shown in Fig. 9 enables highly efficient operation of the propulsion plant with the propeller in combinator mode. In this mode, the propeller and the main engine run at variable speed (typically between 75 to 100 % of nominal rpm). This is a very economical mode because, for low ship speeds, a reduction of propeller speed is more beneficial than a reduction of the propeller pitch when it comes to saving fuel oil.

The propulsion plant can operate at the optimal duty points at all vessel speeds. The diesel engine and the propeller contribute to fuel oil saving in this mode.

In mode two, the VSD unit is used to generate a constant output frequency and voltage towards the main switchboard, so the (variable speed) PTO can run in parallel with the auxiliary gensets. The PTO can even be the only source of electric power generation.

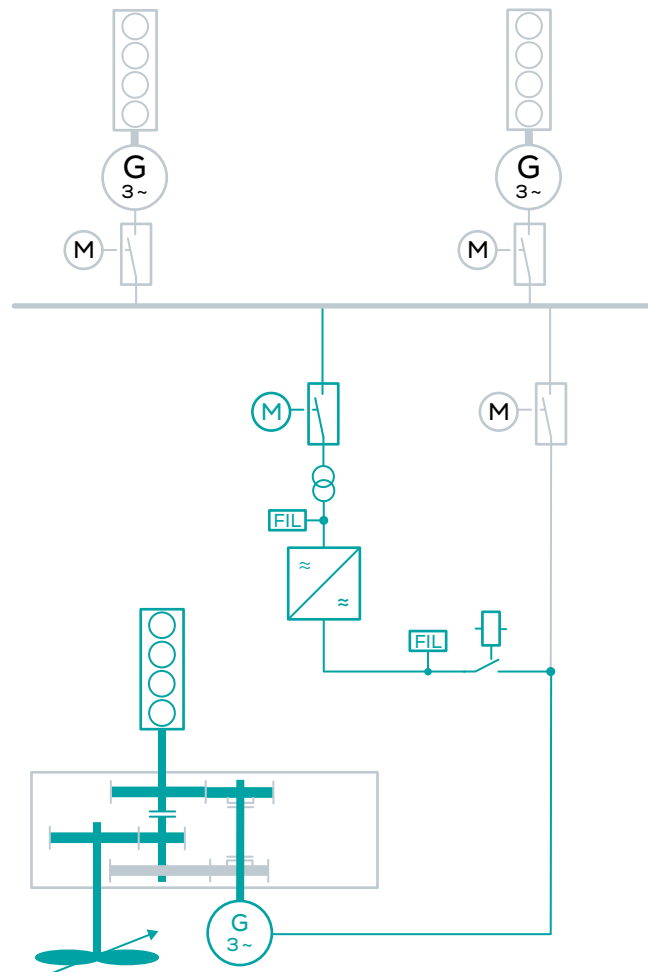

Fig. 9
Gensets can operate in parallel with PTO eco

Mode three: PTO eco floating

Mode three is also a fuel-saving mode similar to mode two PTO eco, as the main engine and the propeller can operate at variable speed (combinator mode).

The auxiliary gensets do not run in mode three. The main engine operates at a variable speed within 83 to 100 % of its rated speed, which means that the frequency on the main switchboard is floating between 50 and 60 Hz. This has to be considered in the layout of the electric consumers.

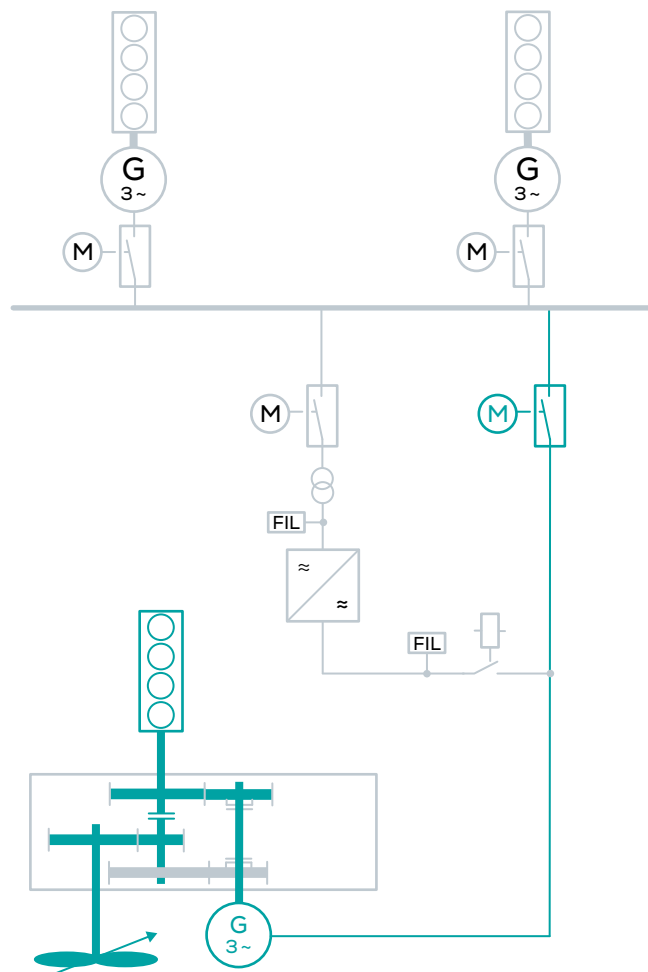

Fig. 10
Gensets are OFF.
Floating frequency on the
main switchboard

Mode five: PTH classic

Mode five is a redundant diesel-electric propulsion mode to be used if the main engine is off. It is often used as emergency propulsion ensuring a take-me-home (PTH) capability for the vessel.

The VSD unit is used for self-starting the shaft machine as PTH motor. The converter is bypassed when the shaft machine has achieved the rated speed, so that in continuous operation there are no electrical losses in the transmission line.

The VSD unit has to be sized for only approximately 25 % of the power of the shaft machine, which is fully sufficient to start it up. The VSD unit can therefore be kept small and light.

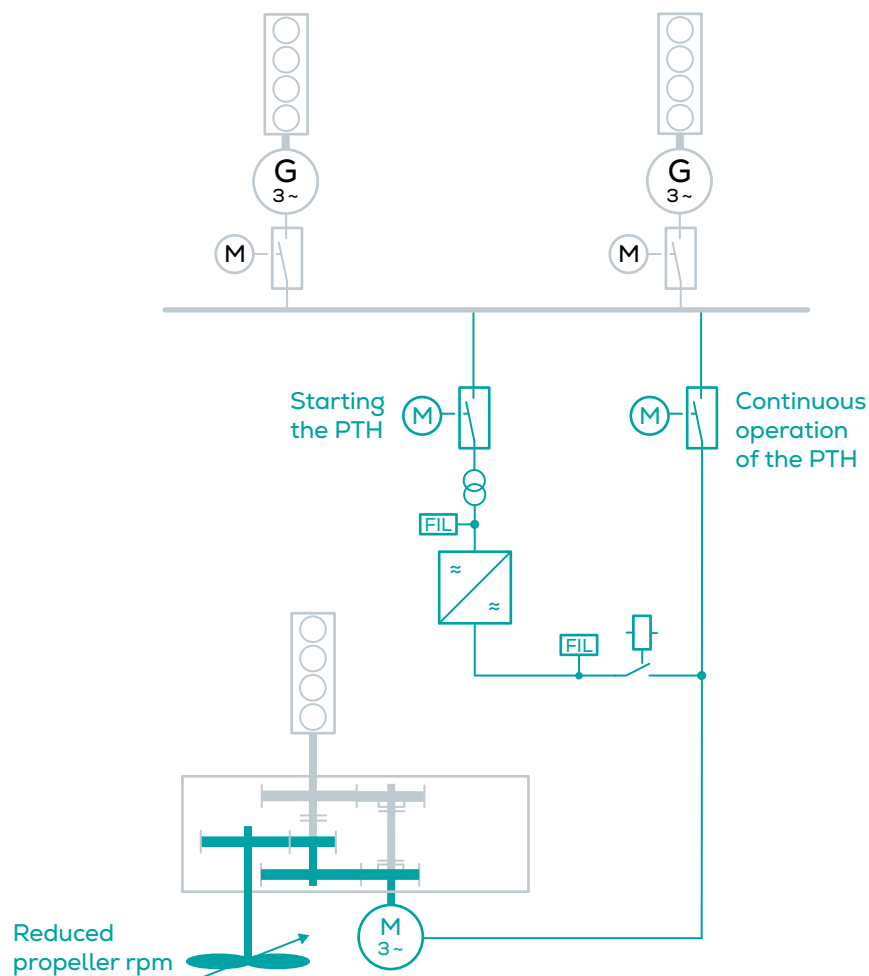

Fig. 12
Gensets are ON

Mode six: DE eco

Mode six is an efficient diesel-electric propulsion mode for slow steaming. At slow ship speeds, it may be more economical to use the shaft machine for electric propulsion instead of running the main engine at low-load. This mode can also be used for take-me-home purposes. The VSD unit and the shaft machine are used to run the propeller at variable speed.

Mode six is an economical electric mode, as the optimal combination of propeller rpm and pitch can be adjusted for every vessel speed.

As the required propulsion power is low in slow steaming ($P_D \sim v_s^3$, according to the propeller law), the VSD unit can be designed with lower power and smaller dimensions.

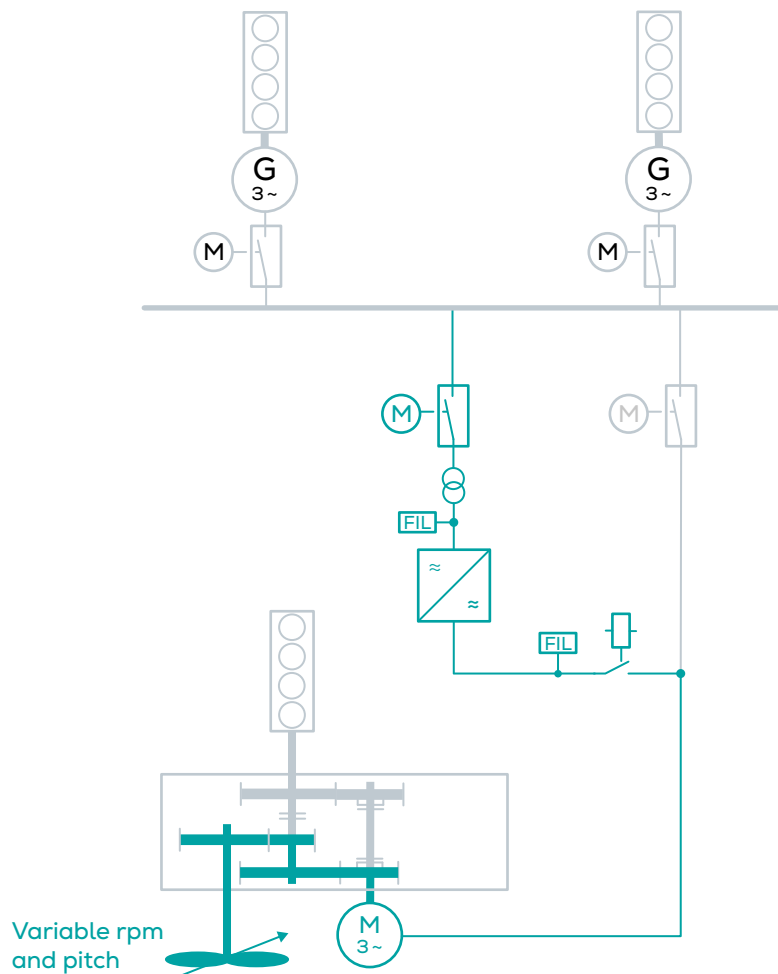

Fig. 13
Gensets are ON

HyProp ECO in action

Purse seiner / trawler

The HyProp ECO system has been successfully deployed on a 77 m purse seiner / trawler built by Karstensens Shipyard, Denmark. The results show that the lower propeller and engine speed saves fuel.

Main machinery and propeller data:

- **Main engine**
1 x 6L32/44CR (1 x 3600 kW)
- **Auxiliary gensets**
2 x 9L16/24 (2 x 990 kW)
- **Gearbox**
1 x two-step ACG 1080 (Scana Volda)
- **VSD unit and shaft machine**
PTO / PTI / PTH (2700 / 1700 / 1400 kW)
- **Propeller**
1 x VBS 1020 CPP (dia. 4.2 m with AHT nozzle and rudder bulb)
- **Propulsion control system**
Alphatronic 3000





© Bernt Sortland

Operation modes

Mode	Ship speed [knots]	Propulsion power [kW]
Sailing to fishing ground	15	2700
Sailing to fishing ground "fast"	16	4200
Sailing to fishing ground "eco"	12	1240
Trawling	3	3000
Free sailing/searching	11	1120
Searching "eco"	9	870
Free sailing to port	14	2195
Free sailing to port "eco"	11	1120
Port	0	0

Table 1: Operation modes



Fig. 14

HyProp ECO in the engine room

The shaft machine (PTO / PTI / PTH) is seen in the foreground and the VSD unit in the background

Efficiency and flexibility combined in a smart manner

- **PTO:** The main engine operates at rated speed and delivers power for the propeller and for the PTO alternator.
- **PTI boost:** The auxiliary gensets deliver additional power to boost the propeller.
- **PTO eco:** The propeller is operated according to the combinator curve with the PTO connected via the VSD unit.
- **Propeller eco:** The propeller is operated at reduced speed and the PTO is used for power generation.
- **DE eco:** The propeller is operated at variable speed and a high pitch setting via the VSD unit.

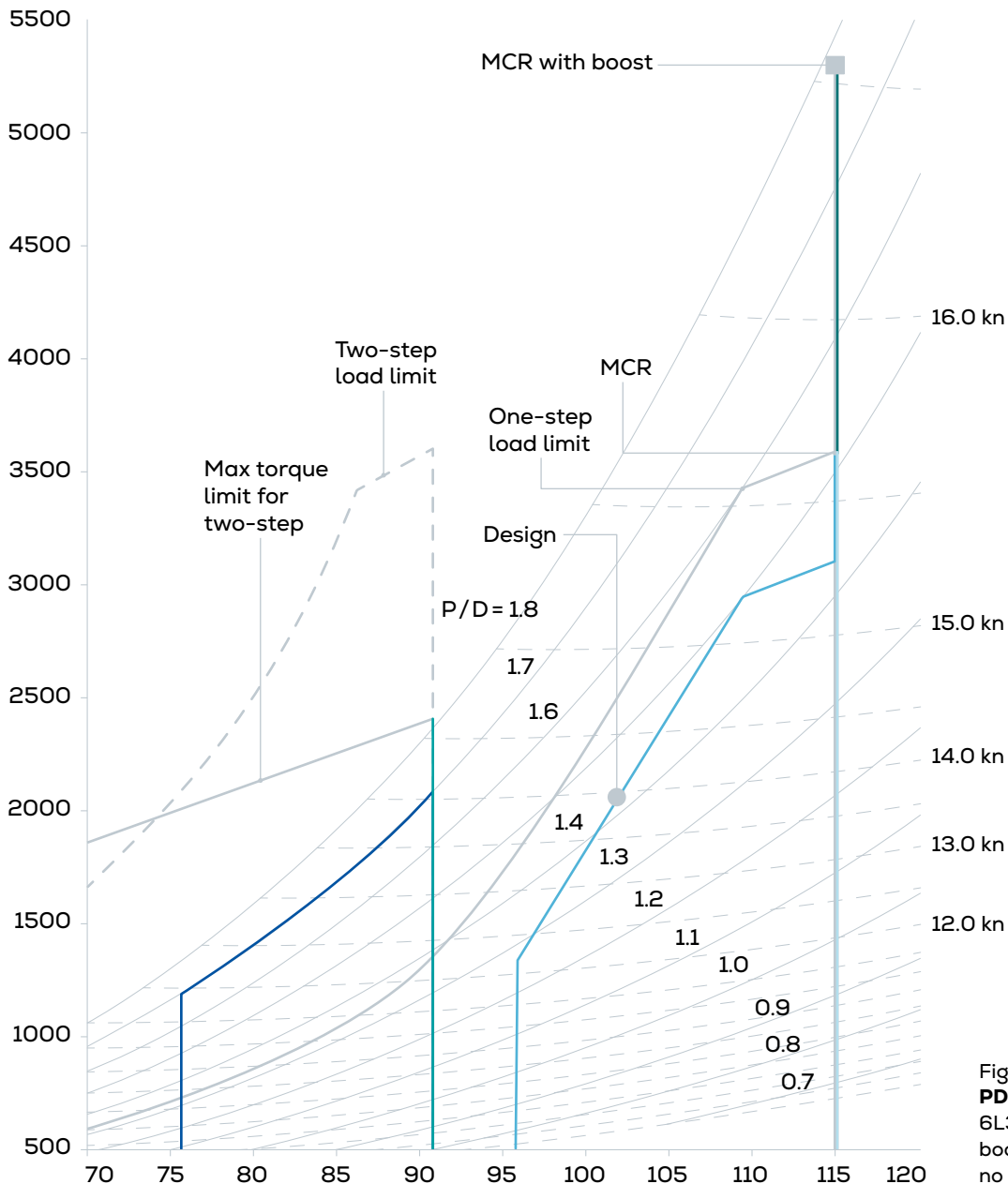

Fig. 15
PD-n diagram
 6L32/44CR with 1700 kW
 boost – design condition –
 no sea margin





Everllence

Everllence

86224 Augsburg, Germany

P + 49 821 322-0

F + 49 821 322-3382

info@everllence.com

www.everllence.com

MAN Energy Solutions SE has been renamed to Everllence SE and its products are being rebranded from "MAN" and/or "MAN Energy Solutions" to "Everllence". As this is an ongoing process, any reference to "MAN" and/or "MAN Energy Solutions" is actually a reference to "Everllence".

All data provided in this document is non-binding. This data serves informational purposes only and is not guaranteed in any way. Depending on the subsequent specific individual projects, the relevant data may be subject to changes and will be assessed and determined individually for each project. This will depend on the particular characteristics of each individual project, especially specific site and operational conditions.

Copyright © Everllence.
EVRO00309EN-250800, GKM-AUG