

L27/38DF-M

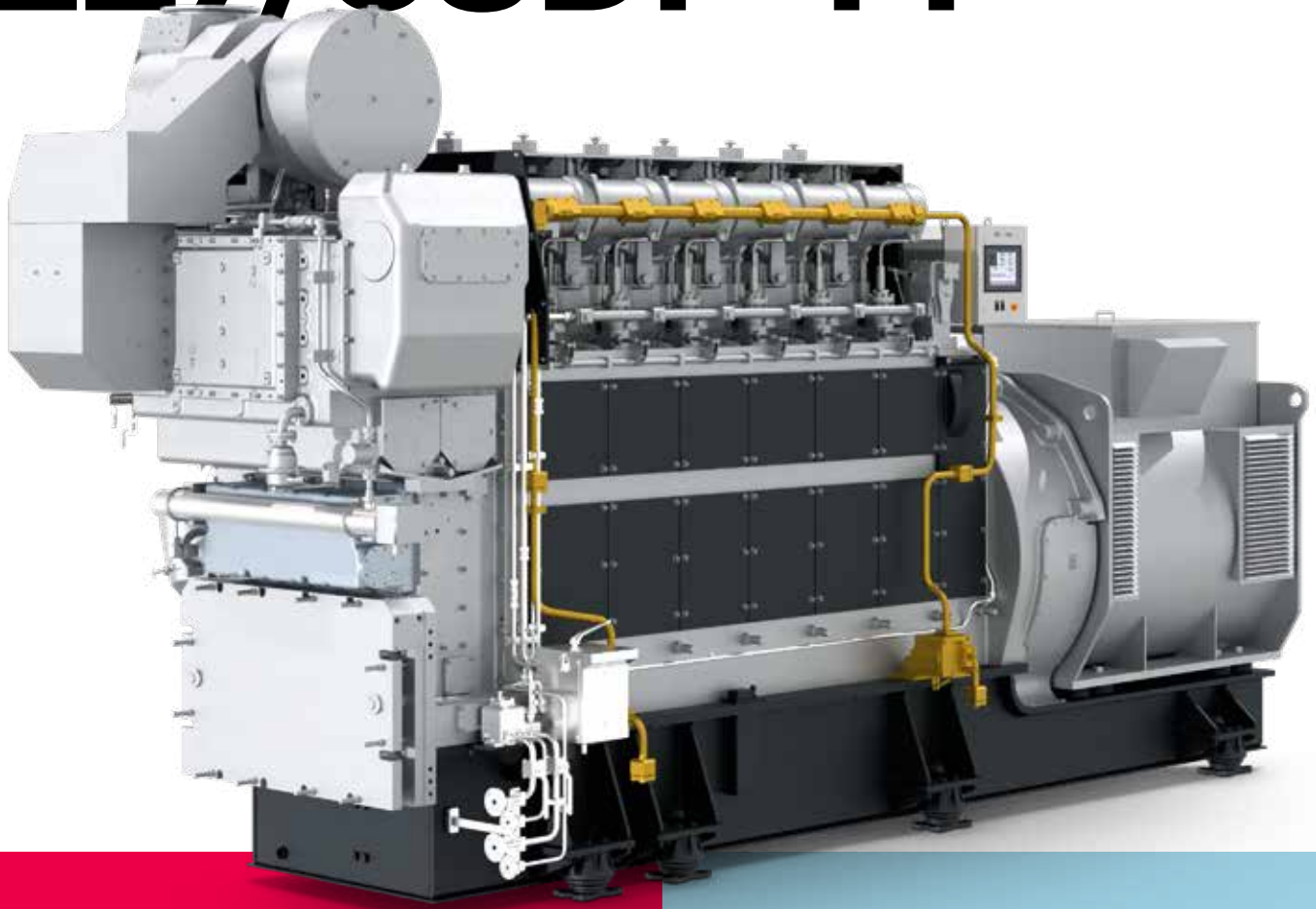

The L27/38DF-M is methanol-fuelled GenSet designed to run on methanol, heavy fuel oil (HFO), and most biofuel oils. It delivers good performance over the entire load range with quick acceleration and immediate load response. Long time between overhauls (TBO) are also valid for the L27/38DF-M and no unscheduled maintenance or repair work are expected.

Benefits at a glance

- Reliable and easy operation
- Long time between overhauls
- Easy maintenance
- Updated to newest family design
- Upgraded to 410 kW/cyl @ 900 rpm
- More than 30 years operation experience with biofuel oil (power plant)
- Approved for ISO2817:2024
- Application as auxiliary GenSet or diesel-electric propulsion

L27/38DF-M

GenSet

Dimensions

Cyl. No.		6	7	8	9
A	mm	4,859	5,304	5,749	6,194
B	mm	2,453	2,811	2,811	2,881
C	mm	7,312	8,115	8,560	9,075
H	mm	4,242	4,429	4,429	4,429
Dry mass	t	43.5	49.3	57.0	63.5

Dimensions depending on alternator selection.

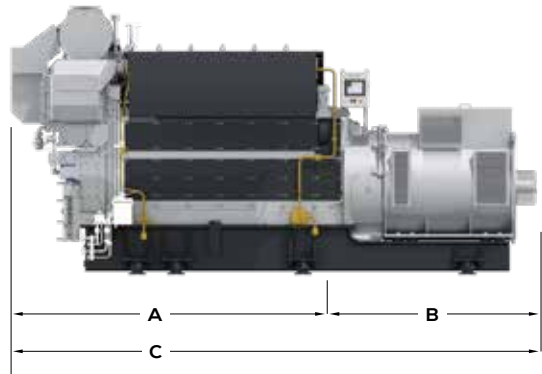

Output

Speed	rpm	750/720	750/720	900	900
Frequency	Hz	50/60	50/60	60	60
		Eng.	Gen.*	Eng.	Gen.*
6L27/38	kW	1,980	1,900	2,460	2,360
7L27/38	kW	2,310	2,220	2,870	2,755
8L27/38	kW	2,640	2,535	3,280	3,150
9L27/38	kW	2,970	2,850	3,690	3,540

* Based on nominal generator efficiencies of 96%

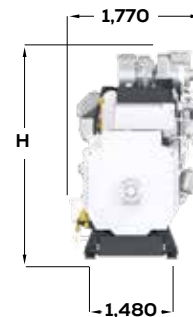

Last updated July 2024

General

- Engine cycle: four-stroke
- No. of cylinders: 6, 7, 8, 9
- Bore: 270 mm – Stroke: 380 mm
- Swept volume per cyl: 21.76 dm³

Fuel consumption at 85% MCR

- At 720 rpm: 181 g/kWh
- At 750 rpm: 182 g/kWh
- At 900 rpm: 186 g/kWh

Cylinder output (MCR)

- At 720/750 rpm: 330 kW/cyl
- At 900 rpm: 410 kW/cyl
- Power-to-weight ratio: 17,5 – 22,5 kg/kW

Compliance with emission regulations

- IMO Tier II
- IMO Tier III (with SCR)

Main features

- **Turbocharging system**
High efficiency constant pressure Everllence TCR series exhaust turbocharging system
- **Engine automation and control**
In-house developed engine attached safety and control system SaCoSone
- **Fuel system**
 - Conventional main injection system
 - Injection system for lowest fuel consumption while meeting IMO Tier II emission limits
- **Cooling system**
1-string high and low temperature cooling water systems
- **Starting system**
Pressurized air starter (turbine type)
- **Engine mounting**
Resilient GenSet mounting

Engine design

- Compact engine design with integrated cooling water/lube oil pumps, thermostatic valves and filters in the front-end box
- Jet assist for improved load response and start-up time, plus prevention of black smoke

Optional equipment

- Preparation for Arctic conditions
- 2-string high and low temperature cooling water systems

MCR = Maximum continuous rating
SCR = Selective catalytic reduction
SFOC = Specific fuel oil consumption

Everllence

2450 Copenhagen SV, Denmark
P + 45 33 85 11 00
F + 45 33 85 10 49
info-cph@everllence.com
www.everllence.com