

L32/44CR

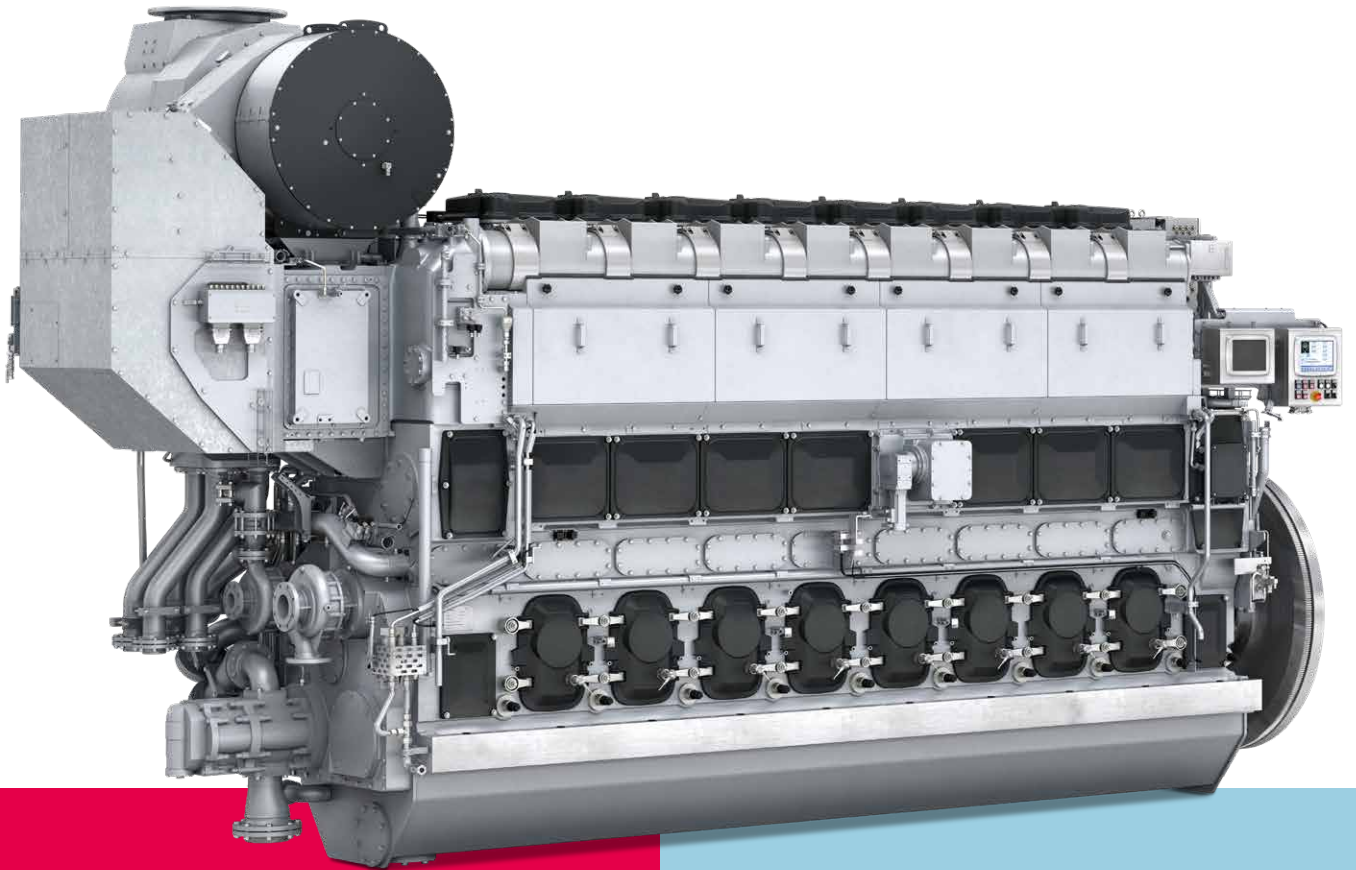

The 32/44CR engine represents the newest technologies in the area of medium speed marine diesel engines. By using electronic injection, high efficiency turbochargers, electronic hardware, and variable valve timing the 32/44CR is a synthesis of the most advanced large engine technologies available.

Benefits at a glance

- High efficiency
- High specific power output
- Low emissions
- Low operating and life cycle costs
- Long maintenance intervals and service life
- High reliability

L32/44CR

Propulsion

Dimensions

Cyl. No.	6	7	8	9	10
L (mm)	6,312	6,924	7,454	7,984	8,603
L ₁ (mm)	5,265	5,877	6,407	6,937	7,556
W (mm)	2,174	2,359	2,359	2,359	2,359
H (mm)	4,163	4,369	4,369	4,369	4,369
Dry mass* (t)	42.5	48.5	53.5	58.0	63.5

Output

Speed (rpm)	750	720
mep (bar)	27.1	28.3
6L32/44CR (kW)	3,600	3,600
7L32/44CR** (kW)	4,060	4,060
8L32/44CR (kW)	4,800	4,800
9L32/44CR (kW)	5,400	5,400
10L32/44CR (kW)	6,000	6,000

Minimum centerline distance for twin engine installation: 2,500 mm

Speed of 720 rpm for generator drive / constant speed operation only

* Including built-on lube oil automatic filter, fuel oil filter and electronic equipment

** 580 kW/cyl Fixed pitch propeller: 550 kW/cyl, 750 rpm Wet oil sump available upon request

Last updated May 2025

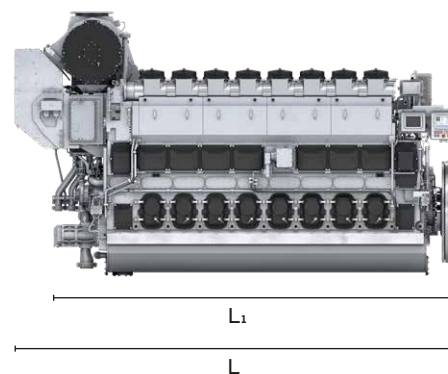
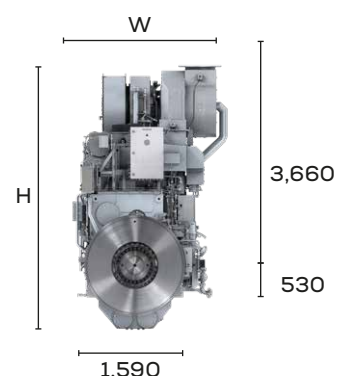

General

- Engine cycle: four-stroke
- No. of cylinders: 6, 7, 8, 9, 10
- Bore: 320 mm – Stroke: 440 mm
- Swept volume per cyl: 35.4 dm³

Fuel consumption at 85 % MCR*

- SFOC: 172 g/kWh
- SFOC: 172,5 g/kWh, 580 kW (7 cyl.)

Cylinder output (MCR)

- At 750/720 rpm: 600 kW
- At 750/720 rpm: 580 kW (7 cyl.)
- Power-to-weight ratio:
9.7 – 11.0 kg/kW

Compliance with emission regulations*

- IMO Tier II
- IMO Tier III (with SCR)
- EPA Tier 2

Everllence

86224 Augsburg, Germany
P + 49 821 322-0
F + 49 821 322-3382
info@everllence.com
www.everllence.com

Main features

Turbocharging system

- High efficiency constant pressure TCR series exhaust turbocharging system

Engine automation and control

- Everllence's in-house developed engine attached safety and control system SaCoS 5000

Fuel system

- Advanced electronic common rail injection system

Lube oil system

- Attached lube oil automatic filter

Cooling system

- 2-string high and low temperature cooling water systems

Starting system

- Pressurized air starter (turbine type)

Engine mounting

- Resilient or rigid mounting

Optional equipment

- ECOMAP concept – using different IMO Tier II compliant injection maps to improve fuel economy
- Additional power take-off at engine free end available

MCR = Maximum continuous rating
SCR = Selective catalytic reduction
SFOC = Specific fuel oil consumption

* According to IMO E2 test cycle

V32/44CR

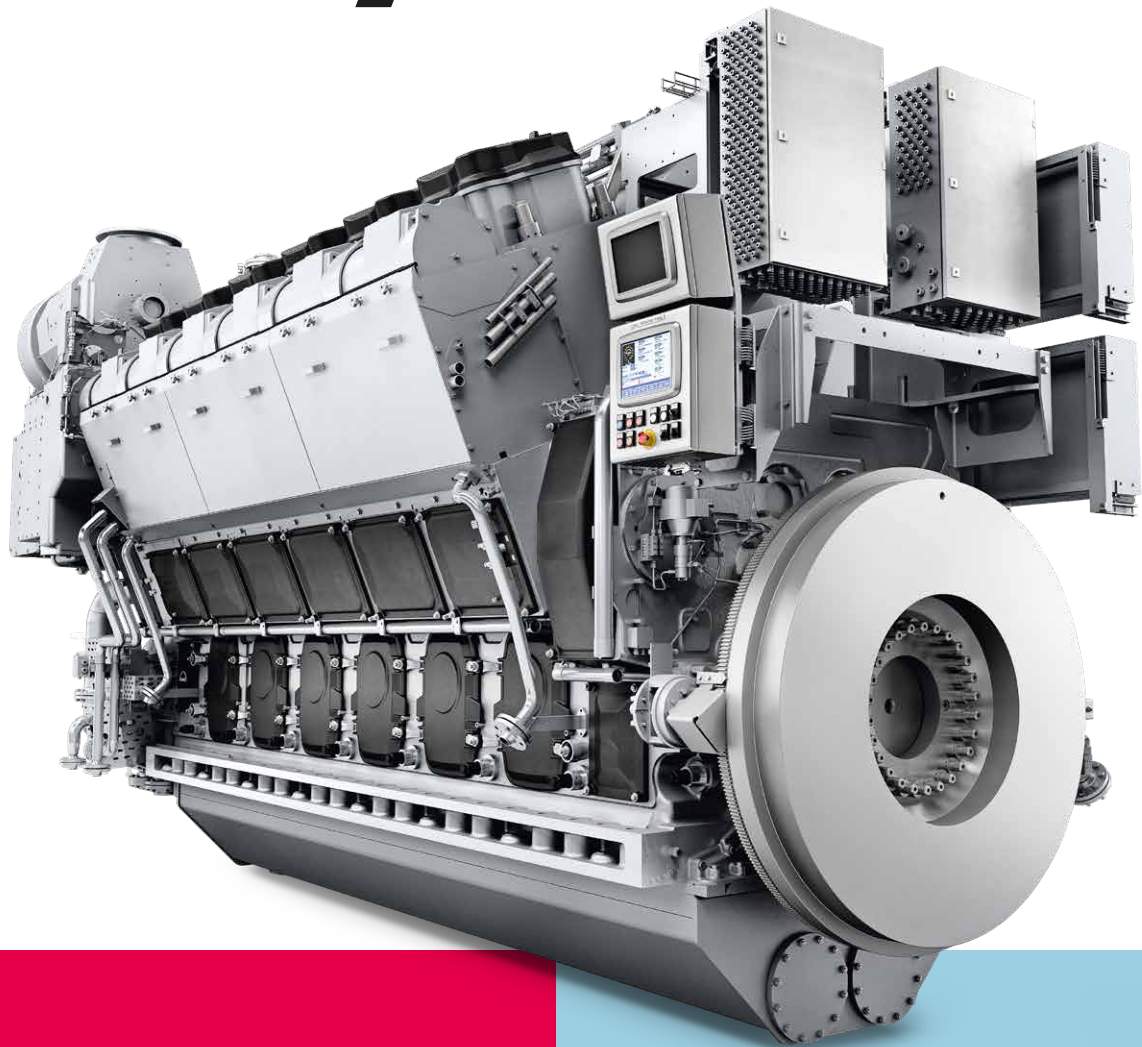

The 32/44CR engine represents the latest technologies in the area of medium speed marine diesel engines. By using electronic injection, high efficiency turbochargers, electronic hardware, and variable valve timing the 32/44CR is a synthesis of the most advanced large engine technologies available.

Benefits at a glance

- High efficiency
- High specific power output
- Low emissions
- Low operating and life cycle costs
- Long maintenance intervals and service life
- High reliability

V32/44CR

Propulsion

Dimensions

Cyl. No.	12	14	16	18	20
L (mm)	7,195	7,970	8,600	9,230	9,860
L ₁ (mm)	5,795	6,425	7,055	7,685	8,315
W (mm)	3,100	3,100	3,100	3,100	3,100
H (mm)	4,039	4,262	4,262	4,262	4,262
Dry mass* (t)	70	82	89	100	106

Output

Speed (rpm)	750	720
mep (bar)	27.1	28.3
12V32/44CR (kW)	7,200	7,200
14V32/44CR** (kW)	8,120	8,120
16V32/44CR (kW)	9,600	9,600
18V32/44CR*** (kW)	10,800	10,800
20V32/44CR (kW)	12,000	12,000

Minimum centerline distance for twin engine installation: 4,000 mm
Speed of 720 rpm for generator drive / constant speed operation only
* Including built-on lube oil automatic filter, fuel oil filter and electronic equipment
** 580 kW/cyl *** 18V32/44CR available rigidly mounted only
Fixed pitch propeller: 550 kW/cyl, 750 rpm Wet oil sump available upon request
Last updated May 2025

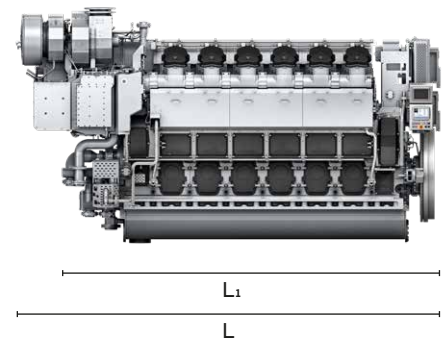
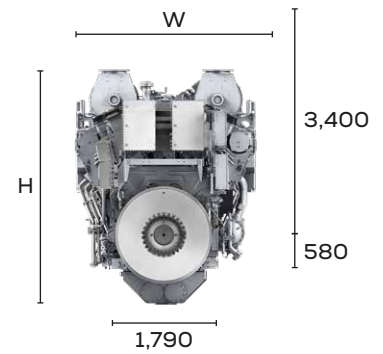

General

- Engine cycle: four-stroke
- No. of cylinders: 12, 14, 16, 18, 20
- Bore: 320 mm – Stroke: 440 mm
- Swept volume per cyl: 35.4 dm³

Fuel consumption at 85 % MCR*

- SFOC: 171 g/kWh
- SFOC: 171,5 g/kWh, 580 kW (14 cyl.)

Cylinder output (MCR)

- At 750/720 rpm: 600 kW
- At 750/720 rpm: 580 kW (14 cyl.)
- Power-to-weight ratio:
8.7 – 9.7 kg/kW

Compliance with emission regulations*

- IMO Tier II
- IMO Tier III (with SCR)
- EPA Tier 2

Everllence

86224 Augsburg, Germany
P + 49 821 322-0
F + 49 821 322-3382
info@everllence.com
www.everllence.com

Main features

Turbocharging system

- High efficiency constant pressure TCR series exhaust turbocharging system

Engine automation and control

- Everllence's in-house developed engine attached safety and control system SaCoS 5000

Fuel system

- Advanced electronic common rail injection system

Lube oil system

- Attached lube oil automatic filter

Cooling system

- 2-string high and low temperature cooling water systems

Starting system

- Pressurized air starter (turbine type)

Engine mounting

- Resilient or rigid mounting

Optional equipment

- ECOMAP concept – using different IMO Tier II compliant injection maps to improve fuel economy
- Additional power take-off at engine free end available

MCR = Maximum continuous rating
SCR = Selective catalytic reduction
SFOC = Specific fuel oil consumption

* According to IMO E2 test cycle