

# 175D

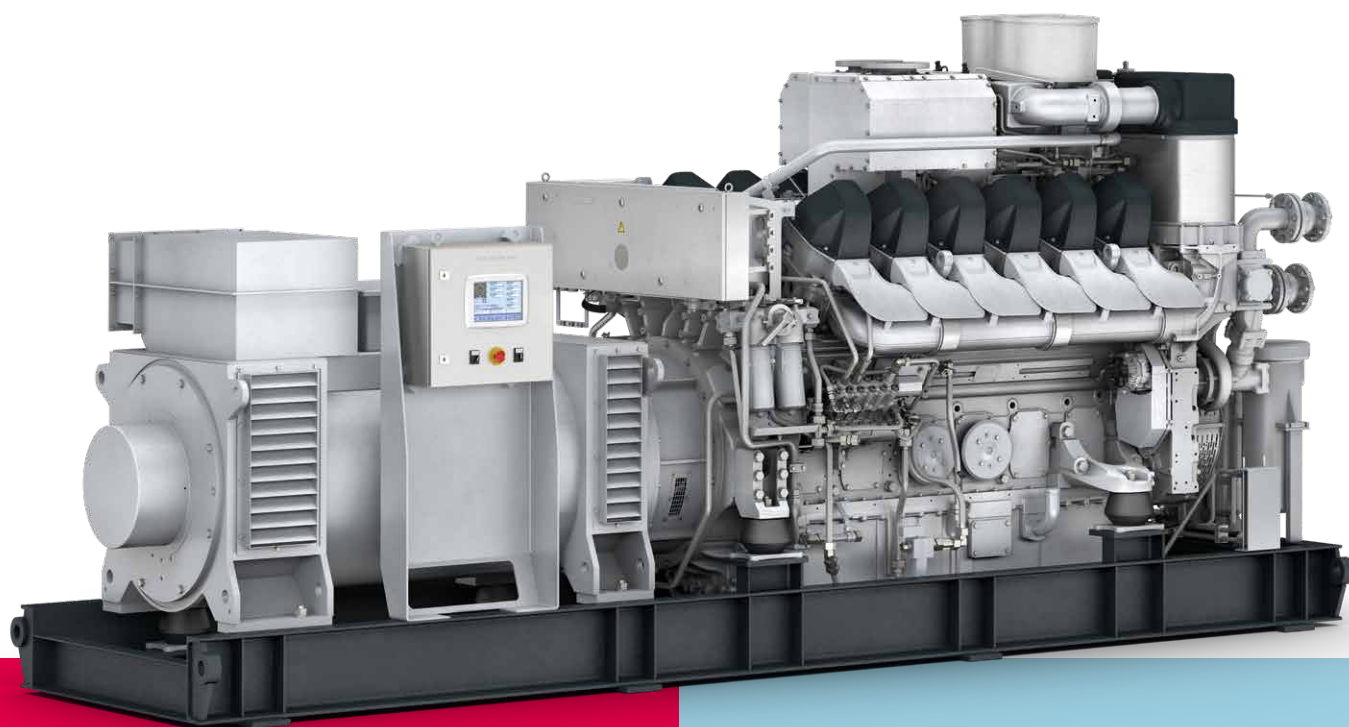

Packing the latest technology into minimal space, the 175D GenSet is characterized by a clear-cut design, flexible ship integration, simple operation, and straightforward maintenance. Its modular design allows it to meet all the challenges of today's different applications.

**Benefits at a glance**

- Low fuel oil consumption
- Low operating costs
- Low life cycle costs
- Long service life

# 175D

GenSet

## Dimensions

Cyl. No.	12V	16V	20V
L (mm)	5,140	5,780	6,300
L <sub>i</sub> (mm)	4,900	5,500	6,000
H (mm)	2,555	2,575	2,555
W (mm)	1,880	1,880	1,980
Dry weight (t)	19.0	22.6	26.8

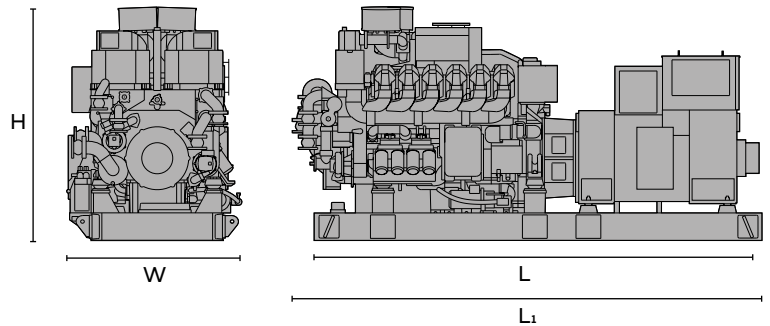

Weight and dimensions are subject to confirmation and have to be adjusted acc. to the various configuration possibilities. Please request installation drawing for planning purposes.

## Output 12V175D

Engine Model	12V175D-MEM				12V175D-MEL			
	Diesel-electric - Medium duty				Diesel-electric - Light duty			
Rating Definitions								
MCR (kW)	1,440	1,620	1,800	1,920	1,800	1,980	2,100	2,280
Rated electrical output (kWe)*	1,382	1,555	1,728	1,843	1,728	1,901	2,016	2,189
Speed (rpm)	1,500	1,500	1,800	1,800	1,500	1,500	1,800	1,800
Average load (%)	75.0	50.0	75.0	50.0	50.0	50.0	50.0	50.0
Frequency (Hz)	50	50	60	60	50	50	60	60
SFOC at 100% MCR, Tier II (g/kWh)	184.0	183.0	190.0	190.5	186.0	186.0	191.0	192.0
SFOC at 100 % MCR, Tier III (g/kWh)	185.0	184.0	191.0	190.5	187.0	187.0	192.0	193.0

Engine Model	12V175D-MEV			12V175D-MA					
	Diesel-electric - Variable Speed			Diesel-electric - Auxiliary					
Rating Definitions									
MCR (kW)	1,860	2,040	2,280	1,620	1,800	1,980	1,920	2,100	2,280
Rated electrical output (kWe)*	1,786	1,958	2,189	1,555	1,728	1,901	1,843	2,016	2,189
Speed (rpm)	1,080	1,080	1,080	1,500	1,500	1,500	1,800	1,800	1,800
	-1,800	-1,800	-1,800						
Average load (%)	75.0	50.0	50.0	50.0	50.0	50.0	50.0	50.0	50.0
Frequency (Hz)	36-60	36-60	36-60	50	50	50	60	60	60
SFOC at 100% MCR, Tier II (g/kWh)	191.0	190.0	192.0	183.0	185.5	186.0	190.5	191.0	192.0
SFOC at 100 % MCR, Tier III (g/kWh)	192.0	191.0	193.0	184.0	186.0	187.5	190.5	192.0	193.0

# 175D

GenSet

## Output 16V175D

Engine Model	16V175D-MEM			16V175D-MEL				16V175D-MEV			16V175D-MA
Rating Definitions	Diesel-el. – Medium duty			Diesel-el. – Light duty				Diesel-el. – Var. speed			Auxiliary
MCR (kW)	2,160	2,400	2,560	2,400	2,640	2,800	2,960	2,480	2,720	2,960	2,400
Rated electrical output (kWe)*	2,074	2,304	2,458	2,304	2,534	2,688	2,842	2,381	2,611	2,842	2,304
Speed (rpm)	1,500	1,800	1,800	1,500	1,500	1,800	1,800	1,080 -1,800	1,080 -1,800	1,080 -1,800	1,800
Average load (%)	50.0	75.0	50.0	50.0	50.0	50.0	50.0	75.0	50.0	50.0	75.0
Frequency (Hz)	50	60	60	50	50	60	60	36-60	36-60	36-60	60
SFOC at 100% MCR, Tier II (g/kWh)	183.0	190.0	190.5	186.0**	186.5**	191.0**	194.0**	191.0	191.0	194.5**	190.0
SFOC at 100% MCR, Tier III (g/kWh)	185.0	192.0	191.5	187.0**	187.5**	192.0**	195.0**	193.0	193.0	195.0**	192.0

## Output 20V175D

Engine Model	20V175D-MEM			20V175D-MEL				20V175D-MEV		
Rating Definitions	Diesel-el. – Medium duty			Diesel-el. – Light duty				Diesel-el. – Variable speed		
MCR (kW)	2,700	3,000	3,200	3,000	3,300	3,500	3,800	3,100	3,400	3,800
Rated electrical output (kWe)*	2,592	2,880	3,072	2,880	3,168	3,360	3,648	2,976	3,264	3,648
Speed (rpm)	1,500	1,800	1,800	1,500	1,500	1,800	1,800	1,080 -1,800	1,080 -1,800	1,080 -1,800
Average load (%)	50.0	75.0	50.0	50.0	50.0	50.0	50.0	75.0	50.0	50.0
Frequency (Hz)	50	60	60	50	50	60	60	36-60	36-60	36-60
SFOC at 100% MCR, Tier II (g/kWh)	183.0	190.0	190.5	186.0	186.5	191.0	192.0	191.0	190.0	192.0
SFOC at 100% MCR, Tier III (g/kWh)	184.5	191.0	190.5	187.0	187.5	192.0	193.0	192.0	191.0	193.0

Rated power output according to ISO 3046-1, ICXN for diesel-electric drives or onboard power generation. The power produced at the flywheel will be within the tolerance of 3% - according to ISO 15550:2002 (E) - up to 45°C (113°F) combustion air temperature measured at the engine air inlet and up to 38°C (100°F) sea or raw water temperature measured at the seawater pump suction inlet, unless other values mentioned explicitly. Specific fuel oil consumption related to mechanical output acc. to ISO 3046-1:2002 based on a lower calorific value of fuel 42,700 kJ/kg with attached lube oil, HT and LT-cooling water pumps fulfilling IMO Tier II/Tier III emission limits with 5% tolerance. Everllence diesel engines are specified according to vibration class 5 of DIN ISO 10816-6 (vibration limit evaluation zone A/B: 28.2 mm/s, rms, 2-1,000 Hz, stationary conditions at nominal operating point)

\* 3-phase, 0.8 p.f., assumes alternator efficiency of 96.0%, class F temperature rise, class H insulation.

Depending on chosen classification society, a de-rating might be required.

\*\*preliminary Last updated May 2025

# 175D

## GenSet

### General

- Standard layout with engine and alternator connected via bellhousing and resiliently seated on the base frame
- Modular common rail fuel injection system
- Integrated lubrication system with electrical prelubrication and extraction pump
- High-efficiency turbochargers
- HT and LT split cooling circuits with integrated pumps and thermostats
- Integrated preheating module
- SaCoS 5000 safety and control system with genset-mounted local operating panel
- Compliant to SOLAS requirements for admissible surface temperature without additional insulation
- Classed by all major Classification societies

### Starting method

- Electric / pneumatic

### Optional equipment

- Air- or freshwater-cooled alternator
- Integrated seawater cooler, engine-driven seawater pump and expansion tank
- Lube oil centrifuge
- Horizontal exhaust gas outlet (12V engine only)
- Double resilient seating
- Redundant starter
- Redundant lube oil supply

### Compliance with emission regulations

- IMO Tier II
- IMO Tier III (with SCR)

MCR = Maximum Continuous Rating  
SCR = Selective Catalytic Reduction  
SFOC = Specific Fuel Oil Consumption

### Everllence

86224 Augsburg, Germany  
P + 49 821 322-0  
F + 49 821 322-3382  
info@everllence.com  
www.everllence.com