

# TCA

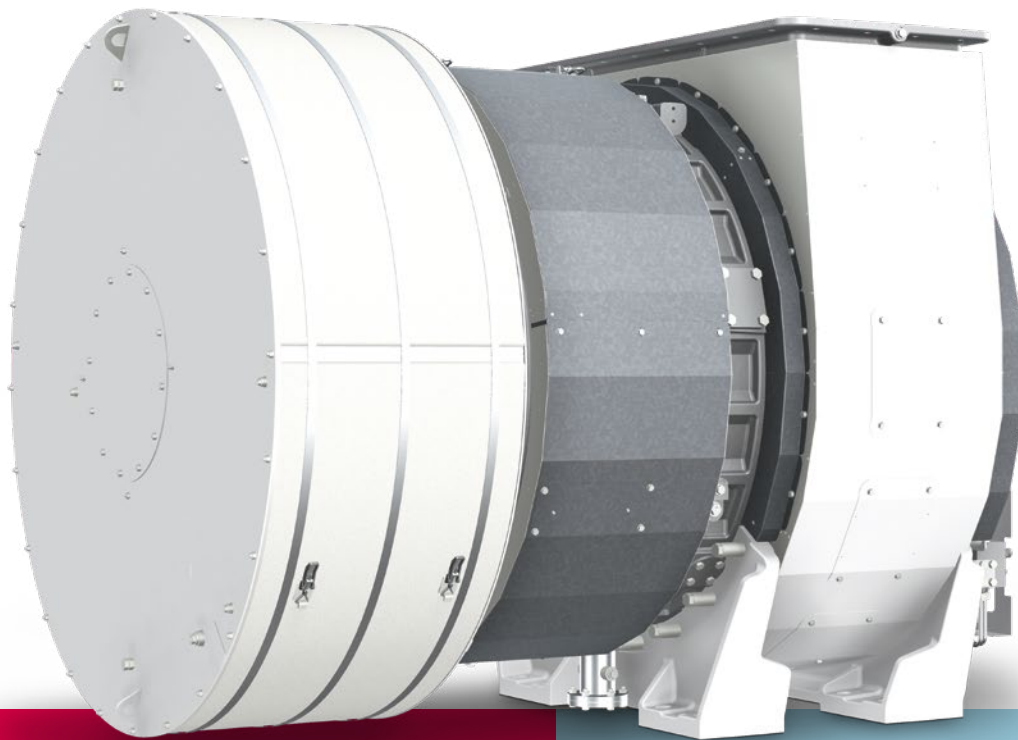

TCA turbochargers are suitable for four-stroke and two-stroke gas, diesel and dual fuel engines in applications ranging from 3 MW up to 30 MW output per turbocharger.

**Benefits at a glance**

Using fewer parts than any other generation of axial turbochargers has reduced maintenance and service times, ensuring lower lifecycle costs.

## Dimensions

Type	L (mm)	B (mm)	H (mm)	Weight (kg)
TCA33	1,558	802	1,021*	1,370
TCA44	2,194**	1,054	1,614	1,950
TCA55	2,167	1,206	1,825	3,200
TCA66	2,360	1,433	2,094	5,300
TCA77	2,782	1,694	2,371	8,330
TCA88	3,316	2,012	2,734	14,000

## Supercharged Engine Output

Type	Two-stroke (kW)	Four-stroke (kW)	Max. permissible Speed (rpm)
TCA33	-	5,400	27,800
TCA44	7,400	7,900	22,700
TCA55	10,200	10,400	20,000
TCA66	14,600	14,800	16,900
TCA77	20,700	21,000	14,200
TCA88	32,400	30,000	12,000

Specific air consumption (le)      7.0 kg / kWh      6.5 kg / kWh

\* Height without gravitation tank, all other heights including gravitation tank. \*\* Gas admission casing 90°. All weights and dimensions are for guidance (project-specific requirements can lead to deviating values). More information available upon request. Last updated June 2023

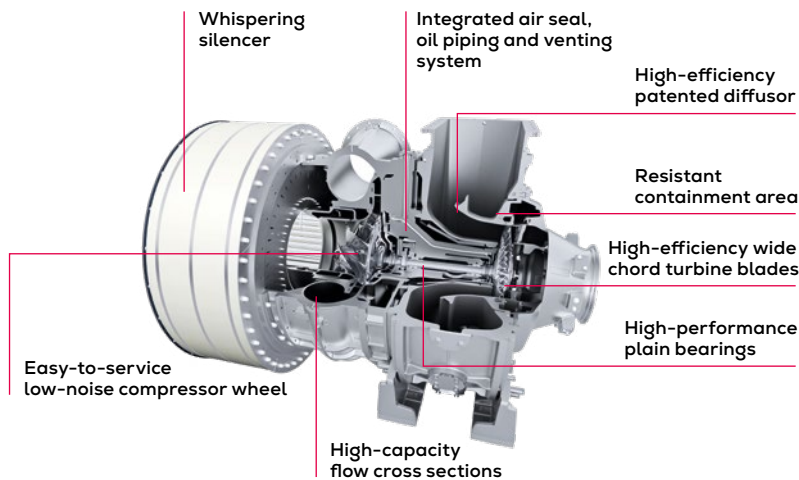
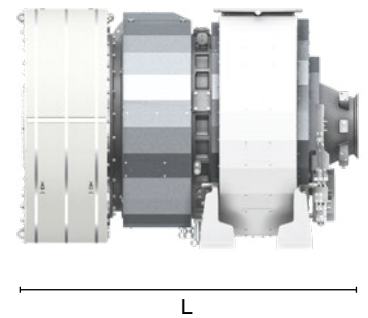
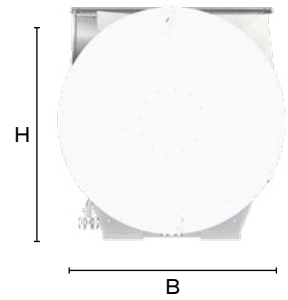

## General

TCA turbochargers are high-performance solutions characterized by ease of maintenance and long overhaul intervals. TCA turbochargers are compliant with IMO Tier II and III and are suitable for all liquid fuels and gases.

## Applications

- Marine propulsion
- Power generation
- Marine GenSets
- Offshore

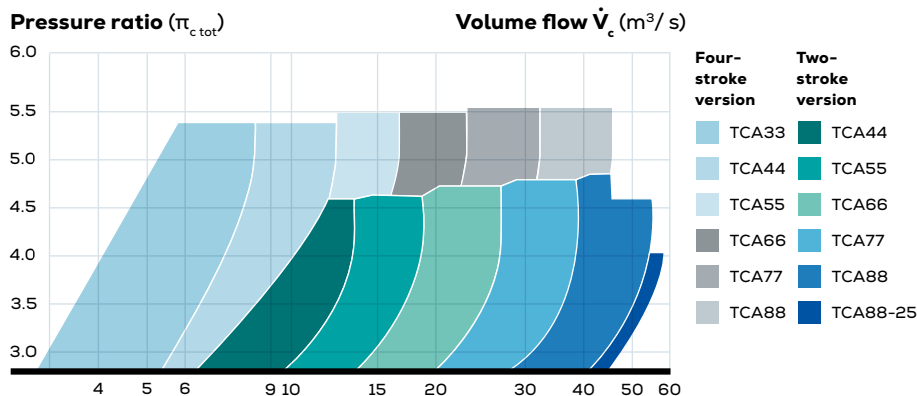

## Contact

**Everllence**  
 86224 Augsburg, Germany  
 P + 49 821 322-0  
 info@everllence.com  
 www.everllence.com